

Easyfitting instructions - newborn

The Easyfit nappy has been designed to be flexible in both fit and absorbency. The effective weight range is from around 8 - 35lbs and will perform exceptionally well if fitted correctly and boosted to your baby's absorbency requirements. The following guide will help you get the best out of your Easyfit nappies on the smaller settings:

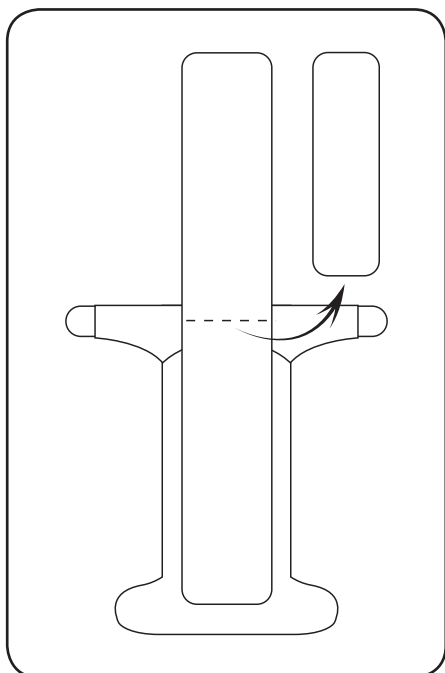

1 - Fold out core and remove additional booster. This pad should only go inside the fold out core when the nappy is in the large setting.

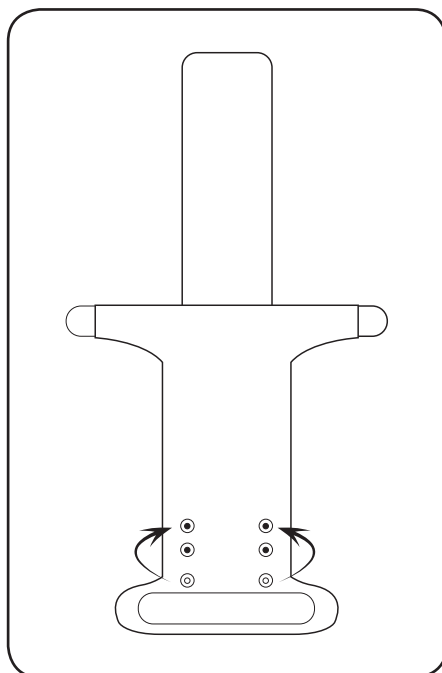

2 - Set size of nappy using poppers on the front.

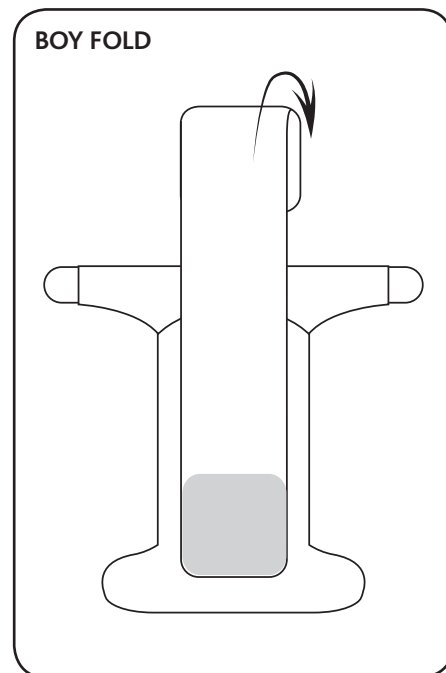

3 - Prior to inserting the core back into the nappy fold the end over as illustrated. This will form a thicker pad towards the front, as indicated by the grey area

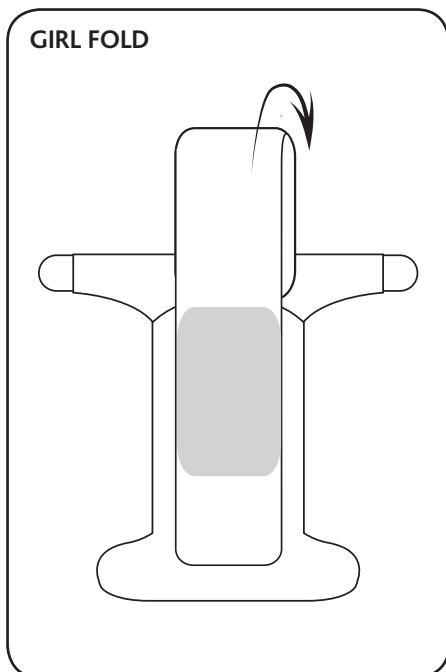

4 - Similar to the boy fold but fold the core in half as illustrated. This will form a thicker pad towards the middle, as indicated by the grey area

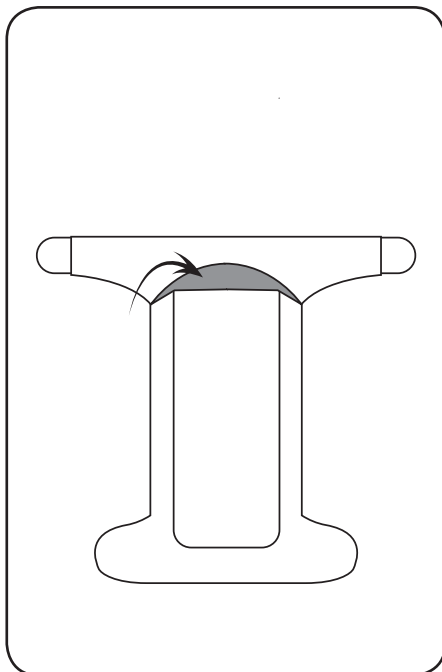

5 - Fold tongue back inside the nappy. NB. the absorbant pad should not ride up into the back of the nappy. It should fold where the terry joins the PUL as illustrated.

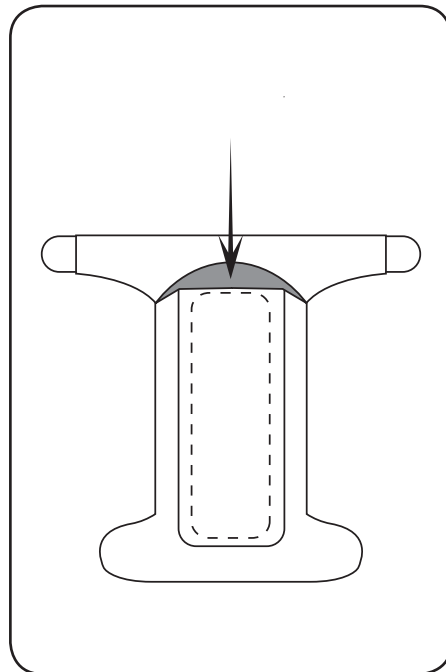

6 - Insert additional pad inside the main pocket if required. It should be positioned as indicated by the dotted line.